



The Yarn. The Web. The Experience.

Subscribe to Caron Connections, our free eNewsletter

Enter your e-mail address

subscribe

Home

Yarns

Pattern Boutique

Gallery

Guide to Style

Cari's Blog

Where to Buy

Boston Cardigan

designed by
Susan Shildmyer



Technique used: Knit



INTERMEDIATE

YARN

Naturally Caron.com Country

(75% Microdenier Acrylic, 25% Merino Wool; 3 oz/100 g, 185 yds/170 m ball): 9 (9, 12, 12, 12, 12)

oz

Shown in: #0001 Rose Bisque

One pair size US 6 (4 mm), or size to obtain gauge

Cable needle

Stitch markers

Stitch holders

Yarn needle

Five buttons – size 5/8" (16mm) diameter

Row counter (optional)



Click for audio fashion show



click to enlarge
schematic | chart

Printer Friendly instructions

SIZES 6-12 months (18-24 months; Child's sizes 2, 3 and 4)

FINISHED MEASUREMENTS

Chest 20 (22, 23, 24, 25)"/51 (56, 58.5, 61, 63.5) cm

Length 11 (12, 12 1/2, 13 1/2, 14)"/28 (30.5, 32, 34.5, 35.5) cm

Note: Cabled fabric is flexible; choose size accordingly.

GAUGE

In Seed Stitch, 20 sts and 32 rows = 4"/10 cm

In overall Cable pattern, approx 31 sts and 32 rows = 4"/10 cm

ABBREVIATIONS

C4B: Slip 2 sts to cn, hold to back, k2, k2 from cn – slants right.

C4F: Slip 2 sts to cn, hold to front, k2, k2 from cn – slants left.

C6B: Slip 3 sts to cn, hold to back, k3, k3 from cn – slants right.

C6F: Slip 3 sts to cn, hold to front, k3, k3 from cn – slants left.

k1-f/b (increase): Knit next st, then knit it through the back loop.

k2tog (decrease): Knit 2 sts together through the front loops – slants right.

ssk (decrease): Slip 2 sts, one at a time KNITWISE to right-hand needle, return sts to left-hand needle in turned position and knit them together through the back loops (tbl) – slants left.

SPECIAL TECHNIQUES

Yo2: [With the yarn in the knit position, bring it to the front between the needles, [to the purl position], then carry it over the needle], twice ready to knit the next stitch – for buttonhole.

STITCHES USED

Stockinette stitch (St st): Knit on RS, purl on WS.

Reverse Stockinette st (Rev St st): Purl on RS, knit on WS.

1 x 1 Rib (multiple of 2 sts + 1)

Row 1 (RS): K1, * p1, k1; repeat from * across.

Row 2: Knit the knit sts and purl the purl sts as they face you.

Repeat Row 2 for 1 x 1 rib.

Seed Stitch (multiple of 2 sts)

Note: Seed st looks the same on both sides; set up row begins with a WS row.

Row 1: K1, * p1, k1; repeat from * across.

Row 2: Knit the purl sts and purl the knit sts as they face you.

Repeat Row 2 for Seed st.

CABLES

4-st-L Cable– Also see Chart.

Rows 1, 5 and 9: C4F

Row 2 and all WS rows: Purl.

Rows 3, 7 and 11: Knit.

Row 12: Purl.

Repeat Rows 1 -12 for 4-st-L Cable.

4-st-R Cable– Also see Chart.

Work as 4-st-L Cable Panel, working C4B in place of C4F.

6-st-L Cable– Also see Chart.

Row 1: C6F.

Row 2 and all WS rows: Purl.

Rows 3 and 11: Knit.

Rows 5, 7 and 9: C4F.

Row 12: Purl.

Repeat Rows 1 -12 for 6-st-L Cable.

6-st-R Cable Panel– Also see Chart.

Work as for 6-st-L Cable, working C6B and C4B in place of C6F and C4F.

9-st Center Back Cable – Also see Chart.

Note: One half of this Cable panel is worked at each center Front, with the center St st as an edge st; C4B, k1 on left Front – k1, C4F on right Front.

Rows 1, 5 and 9: C4B, k1, C4F.

Row 2 and all WS rows: Purl.

Rows 3, 7 and 11: Knit.

Row 12: Purl.

Repeat Rows 1 -12 for 9-st Center Back Cable.

12-st Cable Panel– Also see Chart.

Rows 1 and 7: C6B, C6F.

Row 2 and all WS rows: Purl.

Rows 3, 7 and 11: Knit.

Row 12: Purl.

Repeat Rows 1 -12 for 12-st Cable.

NOTE

Place a marker (pm) between Cable panels, and before and after Seed st at each side, if desired.

Cable panels, except 12-st panel, slant toward the armhole edge each side of center – see Charts.

BACK

Cast on 77 (85, 89, 93, 97) sts.

(RS) Begin 1 x 1 rib; work even until piece measures 1 (1, 1 1/2, 1 1/2, 1 1/2)" from beginning, end with a RS row.

Setup Row: (WS) Work 5 (6, 8, 10, 9) sts in Seed st, pm; k1 – keep in Rev St st; p4 (4-st-L Cable); k2 (3, 3, 3, 4) – keep in Rev St st; p12 (12-st Cable); k2 (3, 3, 3, 4) – keep in Rev St st; p6 (6-st-L Cable); k2 (3, 3, 3, 4) – keep in Rev St st; p9 (9-st Center Back Cable); k2 (3, 3, 3, 4) – keep in Rev St st; p6 (6-st-R Cable); k2 (3, 3, 3, 4) – keep in Rev St st; p12 (12-st Cable); k2 (3, 3, 3, 4) – keep in Rev St st; p4 (4-st-R Cable); k1 – keep in Rev St st, pm; work 5 (6, 8, 10, 9) sts in Seed st.

Row 1: (RS) Work in Seed st to marker; p1; C4B; p2 (3, 3, 3, 4); C6B, C6F; p2 (3, 3, 3, 4); C6B; p2 (3, 3, 3, 4); C4B, k1, C4F; p2 (3, 3, 3, 4); C6F; p2 (3, 3, 3, 4); C6B, C6F; p2 (3, 3, 3, 4); C4F; p1; work in Seed st to end.

Continue as established, working Seed st at each edge, Rows 1 – 12 of Cable panels, with Rev St st between panels and 1 st in St st at center Back; work even until piece measures 6 (6 1/2, 7, 7 1/2, 8)" from the beginning, end with a WS row.

Shape Armholes

(RS) Bind off 4 (6, 6, 6, 6) sts at beginning of next 2 rows— 69 (73, 77, 81, 85) sts remain.

Work even until armhole measures 4 1/2 (5, 5, 5 1/2, 5 1/2)" from beginning of shaping, end with a WS row; place a marker (pm) each side of center 15 (15, 15, 15, 17) sts for neck.

Shape Neck

(RS) Work across to marker; place center sts on holder for neck; join a second ball of yarn and work to end—27 (29, 31, 33, 34) sts rem each side. Working both sides at same time, at each neck edge, bind off 3 sts twice—21 (23, 25, 27, 28) sts remain for each shoulder.

Bind off remaining sts.

LEFT FRONT

Cast on 39 (43, 45, 47, 49) sts.

(RS) Begin 1 x 1 rib; work even until piece measures 1 (1, 1 1/2, 1 1/2, 1 1/2)" from beginning, end with a RS row.

Setup Row: (WS) P1 (edge st – keep in St st); p4 (4-st-R Cable); k2 (3, 3, 3, 4) – keep in Rev St st; p6 (6-st-R Cable); k2 (3, 3, 3, 4) – keep in Rev St st; p12 (12-st Cable); k2 (3, 3, 3, 4) – keep in Rev St st; p4 (4-st-R Cable); k1 – keep in Rev St st, pm; work 5 (6, 8, 10, 8) sts in Seed st.

Row 1: (RS) Work in Seed st to marker; p1; C4B; p2 (3, 3, 3, 4), C6B, C6F; p2 (3, 3, 3, 4); C6B; p2 (3, 3, 3, 4); C4B; k1. Continue as established, working Seed st at armhole edge, Rows 1 – 12 of Cable panels, with Rev St st between panels and 1 st in St st at center Front; work even until piece measures 6 (6 1/2, 7, 7 1/2, 8)" from the beginning, end with a WS row.

Shape Armhole

(RS) Bind off 4 (6, 6, 6, 6) sts, work to end—35 (37, 39, 41, 43) sts remain.

Work even until armhole measures 2 1/2 (3, 3, 3 1/2, 3 1/2)" from beginning of shaping, end with a RS row.

Shape Neck

(WS) Bind off 6 sts, work to end—29 (31, 33, 35, 37) sts remain.

(RS) Work 1 row even.

(WS) At neck edge, bind off 3 sts twice, then dec 1 st every other row 2 (2, 2, 2, 3) times—21 (23, 25, 27, 28) sts remain for shoulder.

Work even until armhole measures same as Back to shoulder.

Bind off remaining sts.

RIGHT FRONT

Work as for left Front; reversing pattern placement and all shaping.

SLEEVES

Cast on 42 (46, 46, 50, 54) sts.

(RS) Begin 1 x 1 rib; work even until piece measures 1 (1, 1 1/2, 1 1/2, 1 1/2)" from beginning, end with a RS row.

Set up Row: (WS) Beg k1, work 2 (4, 4, 6, 8) sts in Seed st, k1-f/b (1 st increased), pm; p4 (4-st-R Cable); k1-f/b; p6 (6-st-R Cable); k1-f/b; p12 (12-st Cable); k1-f/b; p6 (6-st-L Cable); k1-f/b; p4 (4-st-L Cable); pm, k1-f/b; beg p1, work 2 (4, 4, 6, 8) sts in Seed st—48 (52, 52, 56, 60) sts

Row 1: (RS) Work 4 (6, 6, 8, 10) sts across to marker in Seed st; C4B; p2 – keep in Rev St st; C6B; p2 – keep in Rev St st; C6B, C6F; p2 – keep in Rev St st; C6F, p2 – keep in Rev St st; C4F; work 2 (4, 4, 6, 8) sts in Seed st.

Continue as established, working Seed st at each edge, Rows 1 – 12 of Cable panels, with Rev St st between panels; work even for 3 rows, end with a WS row.

Shape Sleeve

(RS) Beginning this row, inc 1 st each side every 4 rows 11 (11, 13, 13, 13) times, working new stitches into Seed stitch as they become available—70 (74, 78, 82, 86) sts.

Work even until piece measures 7 1/2 (9, 9 1/2, 10 1/2, 11 1/2)" from the beginning, end with a WS row.

Bind off all sts in pattern.

FINISHING

Block pieces to measurements. Sew shoulder seams. Set in sleeves; sew sleeve and side seams.

Button Band: With RS facing, pick up and knit 49 (57, 61, 65, 69) sts along Left Front edge.

(WS) Begin 1 x 1 rib; work even until piece measures 1 (1, 1, 1 1/2, 1 1/2)" from pick-up row.

Bind off all sts in rib.

Buttonhole Band: Place markers for 5 buttonholes along right Front edge, first 1/2" from lower edge, last 1/2" from beg of neck shaping, remaining 3 evenly spaced between.

Work as for Button band until band measures 1/2" from pick-up row, end with a WS row.

Buttonhole Row: (RS) * Work to marker, [k2tog, yo2, ssk] for buttonhole; repeat from * for remaining buttonholes, work to end. On next row, work double yarn over as 2 sts in pattern.

Complete as for Button Band.

Collar: With RS facing, beginning 1/2" in from center Front on Band, pick up and knit 75 (83, 83, 65, 65, 69) sts evenly around neck edge, including sts on holder, end 1/2" in from center Front.



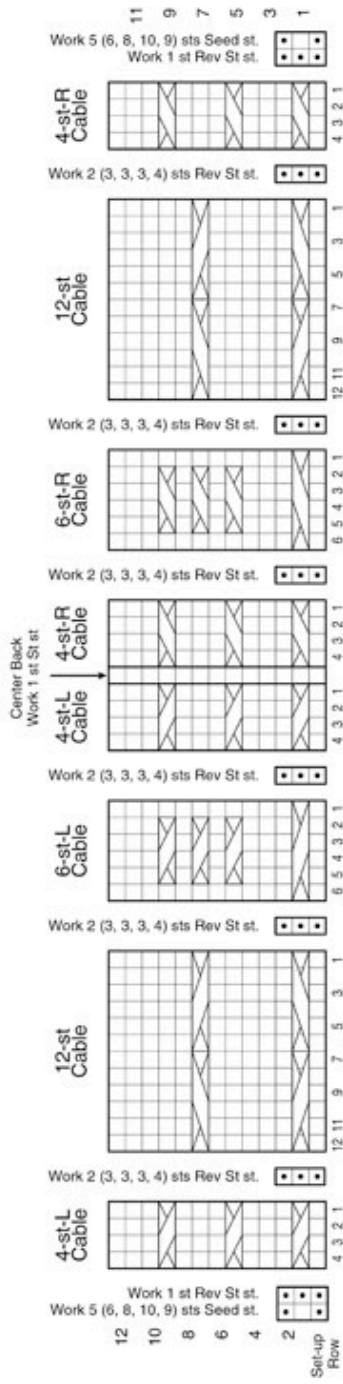

(WS) Begin 1 x 1 rib; work even until piece measures 2 (2 1/2, 3, 3, 3 1/2)" from pick-up row.

Bind off all sts in rib.

Using yarn needle, weave in ends; sew buttons opposite buttonholes.



KEY

- Knit on RS, purl on WS
- Purl on RS, knit on WS
-  C4B: Slip 2 sts to cn, hold to back, k2, k2 from cn.
-  C4F: Slip 2 sts to cn, hold to front, k2, k2 from cn.
-  C6B: Slip 3 sts to cn, hold to back, k3, k3 from cn.
-  C6F: Slip 3 sts to cn, hold to front, k3, k3 from cn.

Seed Stitch

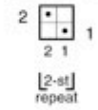

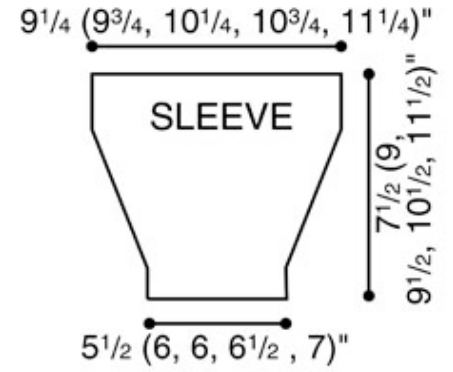
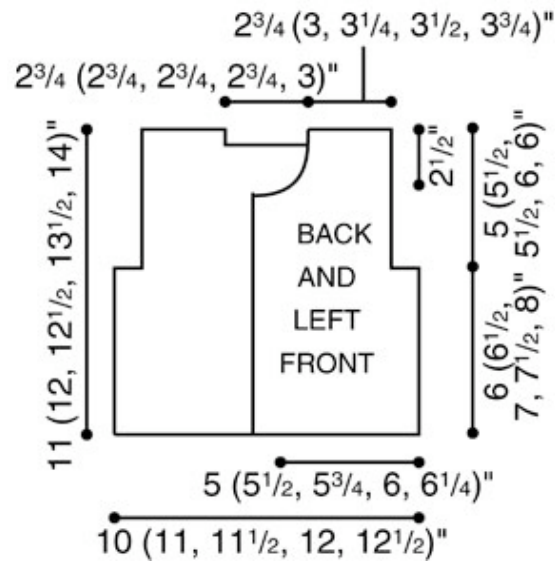

[Visit Bond America online](#)

[Visit Caron International online](#)

CARON

©2008 Caron International