



Subscribe to Caron Connections,
our free eNewsletter

Enter your e-mail address

subscribe

The Yarn. The Web. The Experience.

[Home](#)

[Yarns](#)

[Pattern Boutique](#)

[Gallery](#)

[Guide to Style](#)

[Cari's Blog](#)

[Where to Buy](#)

Kent Vest

designed by
Drew Emborsky



Technique used: Crochet



EASY

YARN

Naturally Caron.com Country

(75% microdenier acrylic/25% merino wool; 3 oz/85 g, 185 yds/169 m skein):

9 (9, 12) oz (A), 3 oz (B), 3 oz (C), 6 oz (D)

Shown in: #0010 Sunset (A); #0022 Plum Pudding (B); #0012 Foliage (C); #0016 Charcoal (D).

One size US I-9 (5.5 mm), or size to obtain gauge.

Yarn needle

Row counter



[click to enlarge](#)

[schematic](#)

[Printer Friendly instructions](#)

SIZES: Small (Medium, Large)

FINISHED MEASUREMENTS:

Bust 32 (36, 40)"/81(91.5, 101.5) cm

Length 25 (25, 27)"/63.5 (63.5, 68.5) cm

GAUGE

In pattern stitch, using I-9 (5.5 mm) hook, 18 sts and 9 rows = 4"/10 cm.

STITCHES USED

Chain (ch), double crochet (dc), single crochet (sc), slip stitch (slip st)

SPECIAL TERMS

FPdc: Front-post double crochet: (RS)Yarn over, insert hook from right-hand side of stitch to WS of piece, return to RS at left-hand side of stitch indicated, yo and pull up loop, complete as dc.

sc2tog: Single crochet 2 together – Insert hook in next stitch, yarn over and pull up a loop, (two loops on hook), insert hook in next stitch, yarn over and pull up a loop, yarn over and draw through all three loops on

hook.

dc2tog: Double crochet 2 together –[Yarn over, insert hook in next st and pull up a loop, yarn over and draw through 2 loops] twice, yarn over and draw through 3 loops on hook.

NOTES

1. Beginning ch 3 counts as first dc.
2. To change color, work last st of old color to last yarn over. Yarn over with new color and draw through all loops on hook to complete stitch. Fasten off old color. Proceed with new color.

MOTIF (make 16)

Make motifs in the following quantities and color sequences:

Motif A (make 2) – Work all 5 (5, 6) rows with D

Motif B (make 1) – Work Rows 1 and 2 with D, Rows 3–5 (5, 6) with C

Motif C (make 2) – Work Rows 1–4 (4, 5) with C, Row 5 (5, 6) with D

Motif D (make 1) – Work Rows 1–3 with D, Rows 4–5 (5, 6) with A

Motif E (make 2) – Work Rows 1–4 (4, 5) with A, Row 5 (5, 6) with D

Motif F (make 1) – Work Rows 1–3 with B, Rows 4–5 (5, 6) with C

Motif G (make 1) – Work Rows 1 and 2 with C, Rows 3–5 (5, 6) with A

Motif H (make 2) – Work Rows 1–4 (4, 5) with B, Row 5 (5, 6) with D

Motif I (make 1) – Work Rows 1 and 2 with B, Rows 3–5 (5, 6) with D

Motif J (make 1) – Work Rows 1–3 with C, Rows 4–5 (5, 6) with B

Motif K (make 1) – Work Rows 1–3 with A, Rows 4–5 (5, 6) with C

Motif L (make 1) – Work Rows 1 and 2 with A, Rows 3–5 (5, 6) with B.

Round 1 (RS): Ch 4 (beginning ch-3 counts as first dc), work 11 dc in fourth ch from hook; join with slip st in top of beginning ch—12 dc.

Round 2: Ch 3 (counts as first dc here and throughout), (dc, ch 2, 2 dc) in same st (corner made), ch 2, skip next 2 sts, *(2 dc, ch 2, 2 dc) in next st (corner made), ch 2, skip next 2 sts; repeat from * around; join with slip st in top of beginning ch—4 corners and 4 ch-2 spaces.

Round 3: Slip st in next st and in first corner ch-2 space, ch 3, (dc, ch 2, 2 dc) in same ch-2 space, FPdc around next 2 dc, ch 2, skip next ch-2 space, FPdc around next 2 dc, *(2 dc, ch 2, 2 dc) in next corner ch-2 space, FPdc around next 2 dc, ch 2, skip next ch-2 space, FPdc around next 2 dc; repeat from * around; join with slip st in top of beginning ch—4 corners, 16 FPdc, and 4 ch-2 spaces.

Round 4: Slip st in next st and in first corner ch-2 space, ch 3, (dc, ch 2, 2 dc) in same ch-2 space, FPdc around next 4 sts, ch 2, skip next ch-2 space, FPdc around next 4 sts, *(2 dc, ch 2, 2 dc) in next corner ch-2 space, FPdc around next 4 sts, ch 2, skip next ch-2 space, FPdc around next 4 sts; repeat from * around; join with slip st in top of beginning ch—4 corners, 32 FPdc, and 4 ch-2 spaces.

Round 5: Slip st in next st and in first corner ch-2 space, ch 3, (dc, ch 2, 2 dc) in same ch-2 space, FPdc around next 6 sts, ch 2, skip next ch-2 space, FPdc around next 6 sts, *(2 dc, ch 2, 2 dc) in next corner ch-2 space, FPdc around next 6 sts, ch 2, skip next ch-2 space, FPdc around next 6 sts; repeat from * around; join with slip st in top of beginning ch—4 corners, 48 FPdc, and 4 ch-2 spaces. Fasten off.

Size Large only:

Round 6: Slip st in next st and in first corner ch-2 space, ch 3, (dc, ch 2, 2 dc) in same ch-2 space, FPdc around next 8 sts, ch 2, skip next ch-2 space, FPdc around next 8 sts, *(2 dc, ch 2, 2 dc) in next corner ch-2 space, FPdc around next 8 sts, ch 2, skip next ch-2 space, FPdc around next 8 sts; repeat from * around; join with slip st in top of beginning ch—4 corners, 64 FPdc, and 4 ch-2 spaces.

All sizes: Fasten off.

BACK

With RS facing, arrange eight motifs into a rectangle, and whipstitch them together, each as follows:

motif J, motif I, motif G, motif E

motif E, motif H, motif F, motif A

Row 1 (RS): With RS facing, join D with sc in top corner of rectangle, work 71 (79, 89) more sc evenly spaced across top edge; change to A in last st, turn—72 (80, 90) sts. Fasten off D.

Row 2: Ch 3, dc in each st across, turn.

Row 3: Ch 1, working in back loops only, sc in each st across, turn.

Repeat last 2 rows until piece measures 16 (16, 17)"/40.5 (40.5, 43) cm from beginning, end with a RS row.

Shape Armhole

Next Row (decrease): Ch 3, dc2tog, dc in each st across to last 2 sts, dc2tog, turn—70 (78, 88) sts.

Next Row (decrease): Ch 1, sc2tog, sc in each st across to last 2 sts, sc2tog, turn—68 (76, 86) sts.

Repeat last 2 rows 2 more times—60 (68, 78) sts.

Next Row: Ch 3, dc in each st across, turn.

Next Row: Ch 1, working in back loops only, sc in each st across, turn.

Repeat last 2 rows 6 (6, 7) more times. Fasten off.

LEFT FRONT

With RS facing, arrange four motifs into a square, and whipstitch them together, as follows:

motif C, motif L

motif H, motif K

Row 1 (RS): With RS facing, join D with sc in top corner of square, work 35 (39, 44) more sc evenly spaced across top edge; change to A in last st, turn—36 (40, 45) sts. Fasten off D.

Row 2: Ch 3, dc in each st across, turn.

Row 3: Ch 1, working in back loops only, sc in each st across, turn.

Repeat last 2 rows until piece measures 16 (16, 17)"/40.5 (40.5, 43) cm from beginning, end with a RS row.

Shape Armhole and Neck

Next Row (decrease): Ch 3, dc2tog, dc in each st to last 2 sts, dc2tog, turn—34 (38, 43) sts.

Next Row (decrease): Ch 1, sc2tog, sc in each st to last 2 sts, sc2tog, turn—32 (36, 41) sts.

Repeat last 2 rows 2 more times—24 (28, 33) sts.

Shape Neck (continued)

Next Row (RS): Ch 3, dc in each st to last 2 sts, dc2tog, turn—23 (27, 32) sts.

Next Row (WS): Ch 1, sc2tog, sc in each st across, turn—22 (26, 31) sts.

Repeat last 2 rows 6 (6, 7) more times—10 (14, 17) sts. Fasten off.

RIGHT FRONT

With RS facing, arrange four motifs into a square, and whipstitch them together, as follows:

motif D, motif B

motif C, motif A

Work as for left front until armhole shaping is complete—24 (28, 33) sts.

Shape Neck (continued)

Next Row (RS): Ch 3, dc2tog, dc in each st across, turn—23 (27, 32) sts.

Next Row (WS): Ch 1, sc in each st to last 2 sts, sc2tog, turn—22 (26, 31) sts.

Repeat last 2 rows 6 (6, 7) more times—10 (14, 17) sts. Fasten off.

BELT (optional)

With color of your choice, ch 7.

Row 1: Sc in second ch from hook and in each remaining ch across, turn—6 sts.

Row 2: Ch 3, dc in each st across, turn.

Row 3: Ch 1, working in back loops only, sc in each st across, turn.

Repeat last 2 rows until piece measures 44 (48, 52)"/112 (122, 132) cm from beginning. Fasten off.

FINISHING

Using yarn needle, weave in all ends. Block pieces to measurements. Sew 2 1/4 (3 1/4, 4)"/5.5 (8, 10) cm shoulder seams. Sew side seams.

Body Edging

Round 1 (WS): With WS facing, join A with sc in center neck edge; work sc evenly spaced around all edges of vest; changing colors as needed to match; join with slip st in first sc. Fasten off.

Round 2 (RS): With RS facing, join D with sl st in back loop of center neck sc, ch 1, sc in back loop of same st, ch 1, sc in front loop of st just made inserting hook from top, skip next st, *sc in back loop of next st, ch 1, sc in front loop of st just made inserting hook from top, skip next st; repeat from * around; join with

slip st in first sc. Fasten off.

Armhole Edging

Work armhole edging around both armholes in same manner as body edging.

Sew center of belt to center of back, just above motifs (optional).

Using yarn needle, weave in all remaining ends.

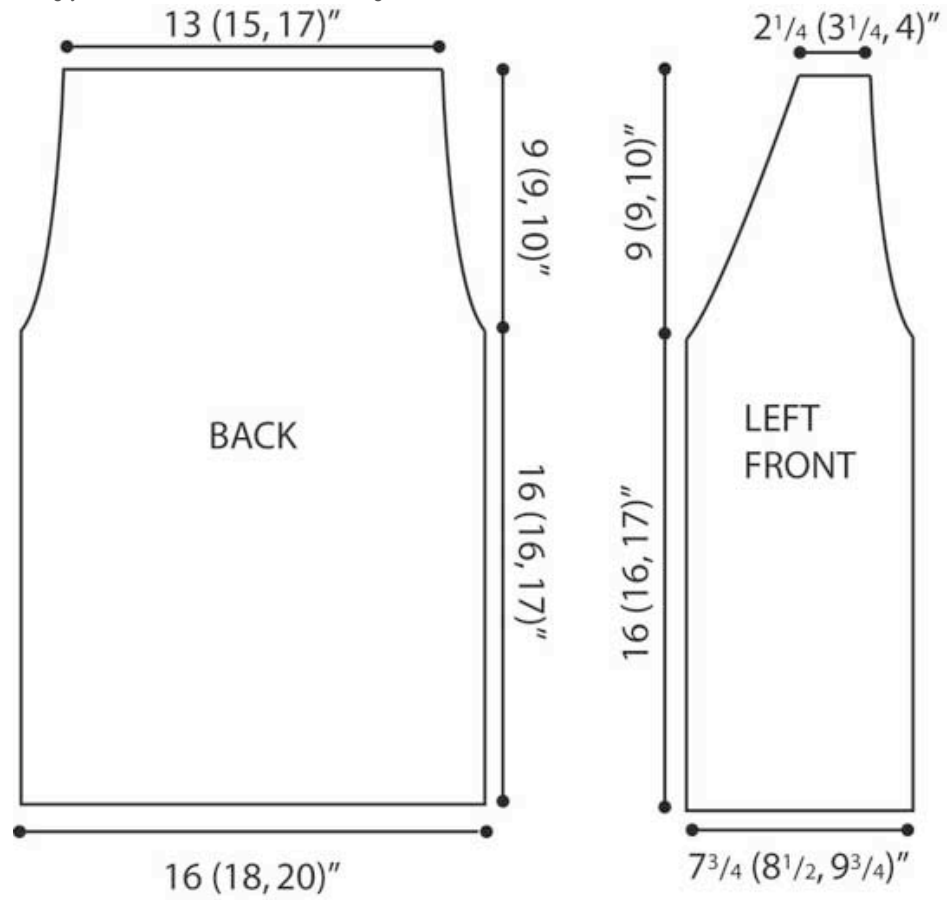

[Visit Bond America online](#)

[Visit Caron International online](#)

CARON

©2008 Caron International